

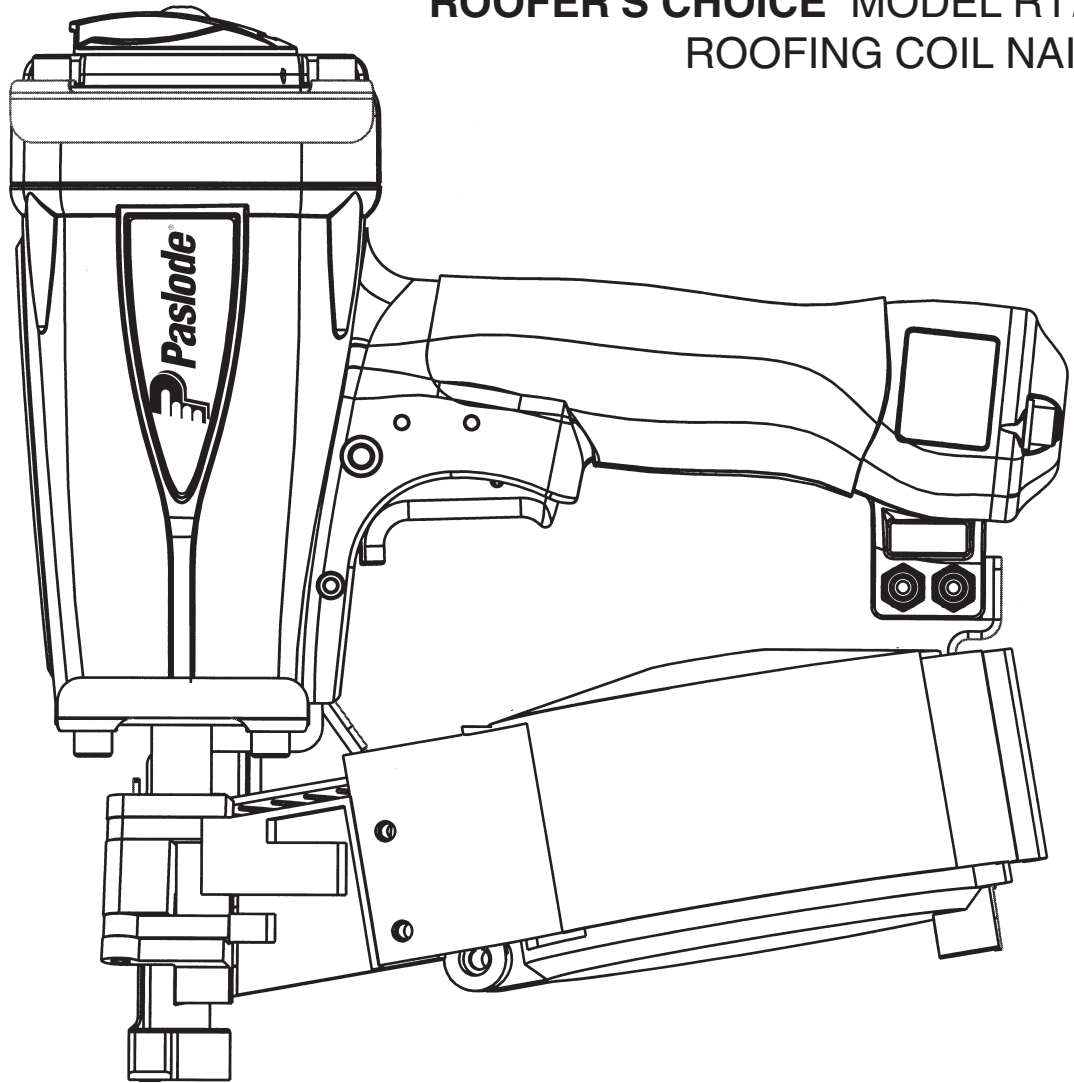

**ROOFER'S CHOICE MODEL R175-C
ROOFING COIL NAILER**



TOOL SCHEMATIC AND PARTS

**IMPORTANT!
DO NOT DESTROY**

Always refer to safety and operating manuals, #403606, #405218 and #405222 for detailed information on this tool. It is the customer's responsibility to have all operators and service personnel read and understand this information.

PARTS LEGEND

R175-C, 501245

1	501043	1	T.H.S.C.S. 1/4-20 x 1/2"	51	500957	1	Housing
2	500956	1	Cap Diffuser	53	097746	1	Pin
3	091362	4	S.H.C.S. 1/4-20 x 1-1/2"	* 54	092174	1	O-Ring
4	501231	1	Cap	55	026133	2	Roll Pin
5	402717	1	Cinical Spring	56	401958	1	Valve Body
* 6	404230	1	Retaining Ring	57	402668	1	Retaining Washer
7	501250	1	Upper Valve Piston	58	501008	1	Lever, Trigger
* 8	091542	1	O-Ring	59	501010	1	Trigger
9	404054	1	Seal, Main Valve	60	501009	1	Roll Pin
10	404056	1	Lower Valve Piston	61	402669	1	Pin, Trigger
* 11	090927	1	O-Ring, Main Valve	62	403573	1	Retaining Ring
* 12	092775	1	O-Ring, Main Valve	63	405233	1	Piston Guide
* 13	092773	1	O-Ring, Main Valve	64	403572	1	Bumper, Feedclaw Piston
* 14	404256	2	O-Ring, Main Valve	65	096815	1	Spring
15	500954	1	Post, Main Valve	66	092709	1	O-Ring
16	015660	1	S.H.C.S. 10-24 x 1/2"	67	405234	1	Piston, Feedclaw
17	403582	1	Driver Blade Nut	68	402031	1	O-Ring
* 18	405430	1	O-Ring, Piston	69	404663	1	Spring, W.C.E.
→ 19	501252	1	Piston	70	009037	2	S.H.C.S. 10-32 x 1/2"
* 20	404001	1	Driver Blade	71	402629	3	Hardened Washer
21	501322	1	Sleeve Retainer	→ 72	501257	1	Intermediate W.C.E.
22	402725	1	Seal Sleeve	73	404004	1	W.C.E.
23	405243	1	Flange Sleeve	74	006057	3	Flat Washer
24	501228	1	Sleeve	▲ 75	004224	3	S.H.C.S. 10-32 x 3/8"
* 25	402728	1	O-Ring, Sleeve	76	501264	1	Logo Label
* 26	091966	1	O-Ring, Sleeve	77	501294	1	Nameplate
* 27	500369	2	O-Ring, Sleeve	78	404015	1	Cover, Magazine
28	501227	1	Bumper Retainer	79	404092	2	Wear Shield, Magazine
29	500975	1	Gasket Cap	80	403579	1	Roll Pin 1/16 x 1/2"
30	501140	1	Logo Housing Left	81	403568	1	Cap, Post
31	501141	1	Logo Housing Right	82	402071	1	Extension Spring, Post
32	402708	1	Gasket Nose Flange	83	403543	1	Nail Plate Assembly
33	501229	1	Bumper	84	404731	1	Center Post, Outer
34	404007	1	Nose Assembly with Magnet	85	403580	1	Retaining Ring
35	092037	7	Locknut	86	403556	1	Center Post, Inner
36	404091	2	Wear Shield Nose	87	005849	2	Roll Pin - 11/16"
37	091545	4	S.H.C.S. 1/4-20 x 7/8"	** 88	500459	1	Warning Label
38	404361	1	Roll Pin	89	404016	1	Magazine
39	404014	1	Door	90	404303	1	S.H.C.S. 10-32 x 1-1/4"
40	404013	1	Front Guide	91	006621	1	S.H.C.S. 10-32 x 7/8"
41	404106	1	S.H.C.S. 10-32 x 2"	92	404019	1	Nut, Shingle Guide
42	404012	1	Holdback Claw	93	404020	1	Shingle Guide
→ 43	501520	2	Spring	94	404018	1	Bracket, Shingle Guide
44	402486	1	Retaining Washer	95	501023	1	Grip Handle
45	402041	1	Torsion Spring, Feedclaw	96	404017	1	Magazine Bracket
46	405001	1	Feed Claw	97	501320	1	Guide Block
47	402488	1	Pivot Pin, Feedclaw	98	501299	2	S.H.C.S. 1/4-20 x 1"
48	404093	1	Debris Shield	99	500963	1	End Plug
49	404002	3	Grommet, Debris Shield	▲ 100	071297	1	Roll Pin 1/8 x 1-1/8"
▲ 50	004502	4	S.H.C.S. 10-32 x 5/8"	101	404010	1	Magnet
				102	501253	2	Shield/Wear Cap

* Denotes normal wear items.

** Make sure warning label (500459) is properly affixed. Replace if necessary. Label available at no charge through the Service Dept.

▲ Apply Loctite 242 (Blue)

→ Denotes new change

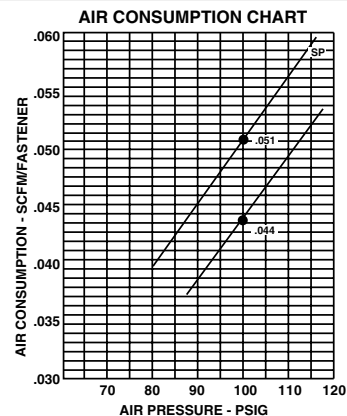

R175-C
501245

